

Time for Progress...

FINE WIRE MESH
FLAT TOP WIRE SCREEN
HARP WIRE SCREENS
PIANO WIRE SCREENS
FINGER SCREEN
PERFORATED SCREEN
RUBBER SCREENS MODULAR - ECOGUM
POLYURETHANE SCREEN TENSIONED
POLYURETHANE SCREEN MODULAR
SLOTTED WEDGE WIRE SCREENS
PRESSURE WELDED SCREEN - PROGRESS TYTAN

Rubber screens

Tensioned



Producer of industrial screens



www.progress-screens.com

RUBBER SCREENS



Progress ECOGUM rubber screens are produced for all types of sorting equipment. Designed mainly to sort products ranging from 4,0 up to 200 mm. Modern production technology and high class rubber compounds, allow to choose from a large variety of thickness measurements, bridge wideness and opening placements, depending on screen's usage and requirements. The thickness can be from 4,0 up to 200 mm. There are 3 available versions: in round, square or rectangular shapes. Mat thickness can be from 5,0 up to 60,0 mm, and is produced in three versions:



TENSIONED RUBBER SCREENS WITH CORD REINFORCEMENT

Their main advantage is the ability of substituting wire screens without changing the underscreen construction. Mainly used when screen plugging appears and high effectiveness is required. They are side and end tensioned. Produced from abrasion resistant rubber, reinforced with a cord, suitable for all types of vibrating screening machines.



Tensioned screens are available with following tensioning systems:

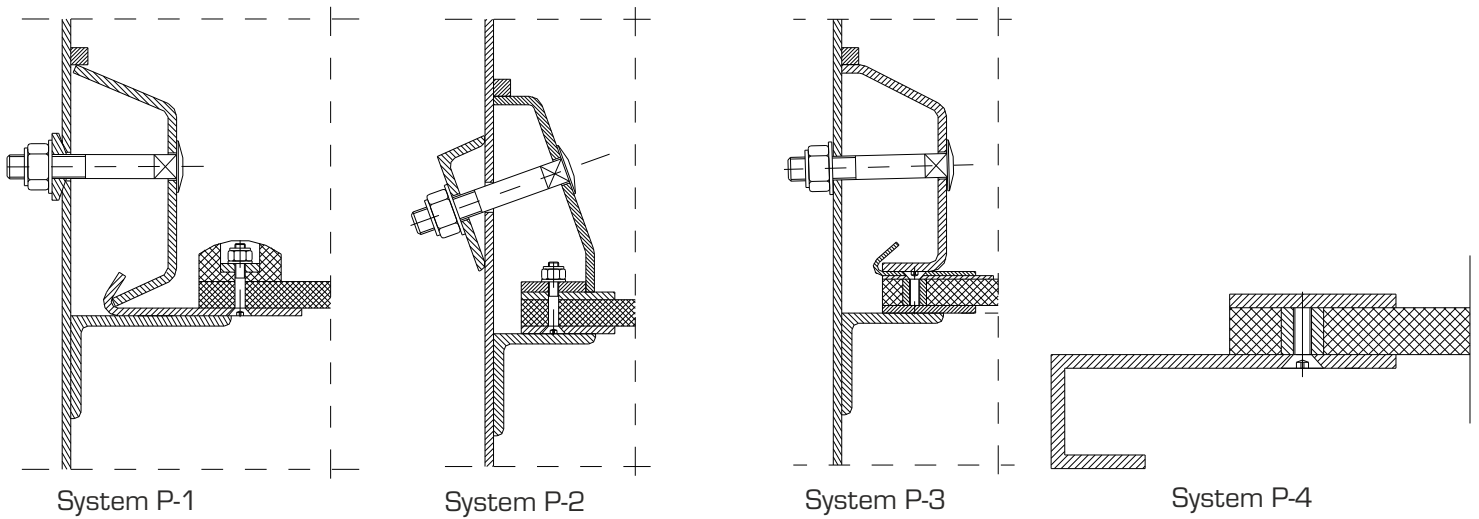

RUBBER SCREENS WITH STEEL FRAME AND CORD

REINFORCEMENT can pose as a self – supporting deck, suitable for tougher work conditions – mainly for big fractions classification. They are mounted using side rubber bars.



RUBBER SCREENS WITH STEEL FRAME, made of angle bar and steel rods – can also pose as a self – supporting deck, used mainly for prescreening in tough conditions. They are mounted using side rubber rods.

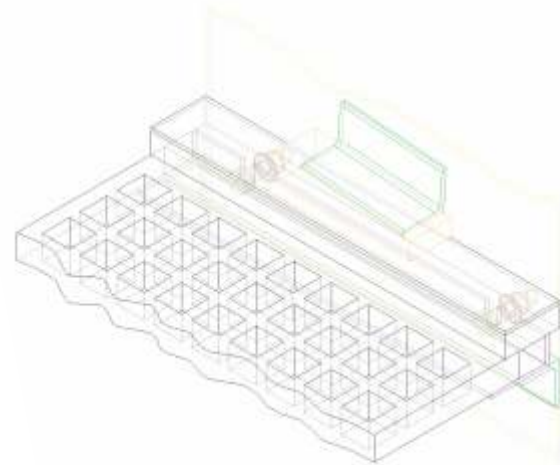
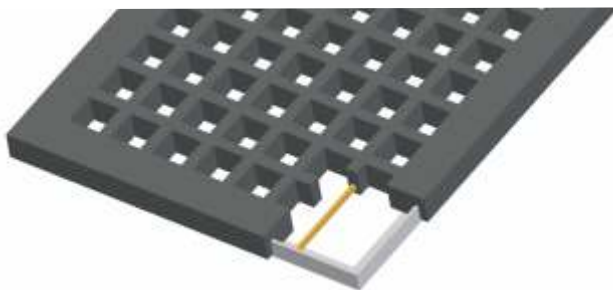

PROGRESS rubber screens dimensions are individually adapted for machine dimensions and work conditions. They are particularly recommended for prescreening machines, working in continuous cycle.

Our offer also includes rubber lining, which can be used for example inside loads or charging hoppers.

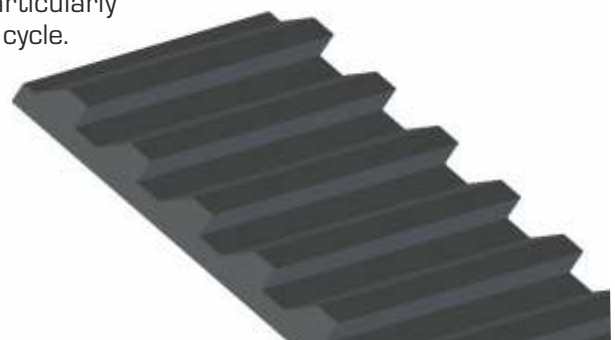



www.progress-screens.com



Progress Eco S.A.
Dobrów 7, 28-142 Tuczępy, Poland

International Sales Working hours: Monday - Friday / 8:00-16:00 UTC+1
T: +48 41 346 50 06 (ext. 120) F: +48 41 346 50 08 E: sales@progress-screens.com

www.progress-screens.com

